

Operating Instructions

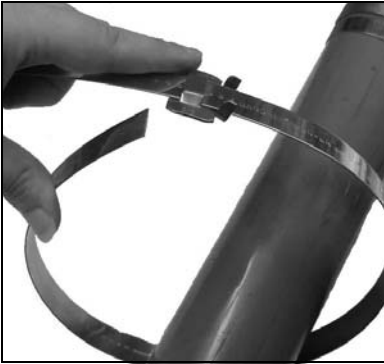

C00169 Hand Tool



1. Band may be used from bulk roll as this *completely eliminates waste of band*. Slide buckle on band as shown, bringing end of band around object to be clamped and again through buckle. **NOTE:** *The tension screw thread should be lubricated regularly.*

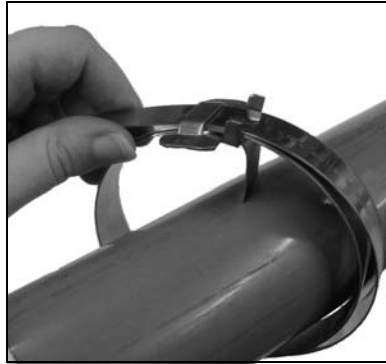

2. Continue band around object once more and again through buckle. *Double banding develops a great deal more radial compression than single banding.* Bend end of band under buckle.

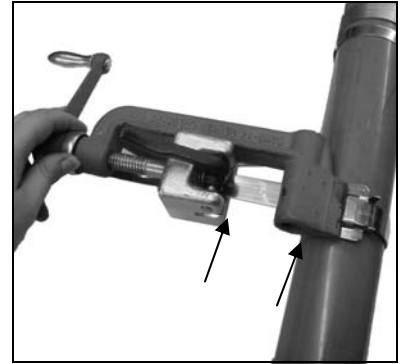

3. Place band in opening of tool nose and gripper block. Move into slot as far as possible, to avoid buckle sliding into tool nose. Tighten band clamp by turning the tension handle clockwise while holding band gripper tight against band. **NOTE:** *The spring load of the band gripper is not intended to secure and prevent band from slipping during tension process.*



4. Place finger on BAND-IT Band at buckle bridge while tensioning with tool handle. When you feel BAND-IT Band stop moving through buckle as you are turning handle, *maximum pressure is being exerted by the BAND-IT Band* around object being clamped. *Stop turning handle.*



5. *Roll tool over buckle, backing off with tension handle throughout entire rolling operation.* Failure to back off with tension handle throughout entire course of roll-over may result in breaking of band. There is no loss of tension as band released is used up in the bend.



6. Pull cutting handle to cut the band.

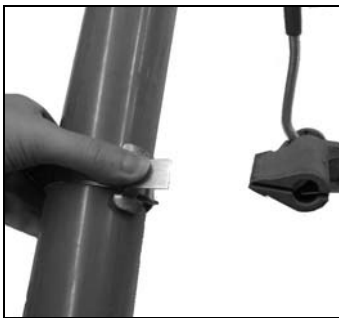

7. Remove tool, holding stub of band down with thumb.



8. Hammer down buckle ears to hold band stub in place to complete BAND-IT clamp.

Gripper Cleaning Instructions:



1. Remove gripper. Align gripper pin hole with notch in tool frame. Using a punch and hammer, punch pin out of slide block.



2. Using a wire brush, clean all foreign matter from teeth.



3. Replace pin. Gripper spring must be seated in tension screw hole. Align gripper hole with slide block hole, insert pin in hole and hammer pin in place.

Scru-Lokt Buckles:



1. The BAND-IT Scru-Lokt clamp, using the Scru-Lokt buckle, is applied in exactly the same way as the BAND-IT clamp except that the tool is not rolled over.



2. After tension is applied, insert set screw in Scru-Lokt buckle and tighten. To permit taking up Scru-Lokt clamp, or to re-use, a 3 inch (7.5 cm) stub should be left so that tool will be able to re-grip band later.



3. Where stub of band is left for Scru-Lokt clamp, it may be folded under as shown.

Tool Accessories:

JR Adapters: The JR adapters (J00169 and J05069 heavy duty) are used with the BAND-IT C00169 tool when BAND-IT JR. preformed clamps are used.

C04388 Close Quarter Tension Nut: In cramped quarters, use instead of tool tension handle.

NOTE: See general catalog or web site for instructions and ordering information.

Tool Assembly Parts List



C00169 Hand Tool

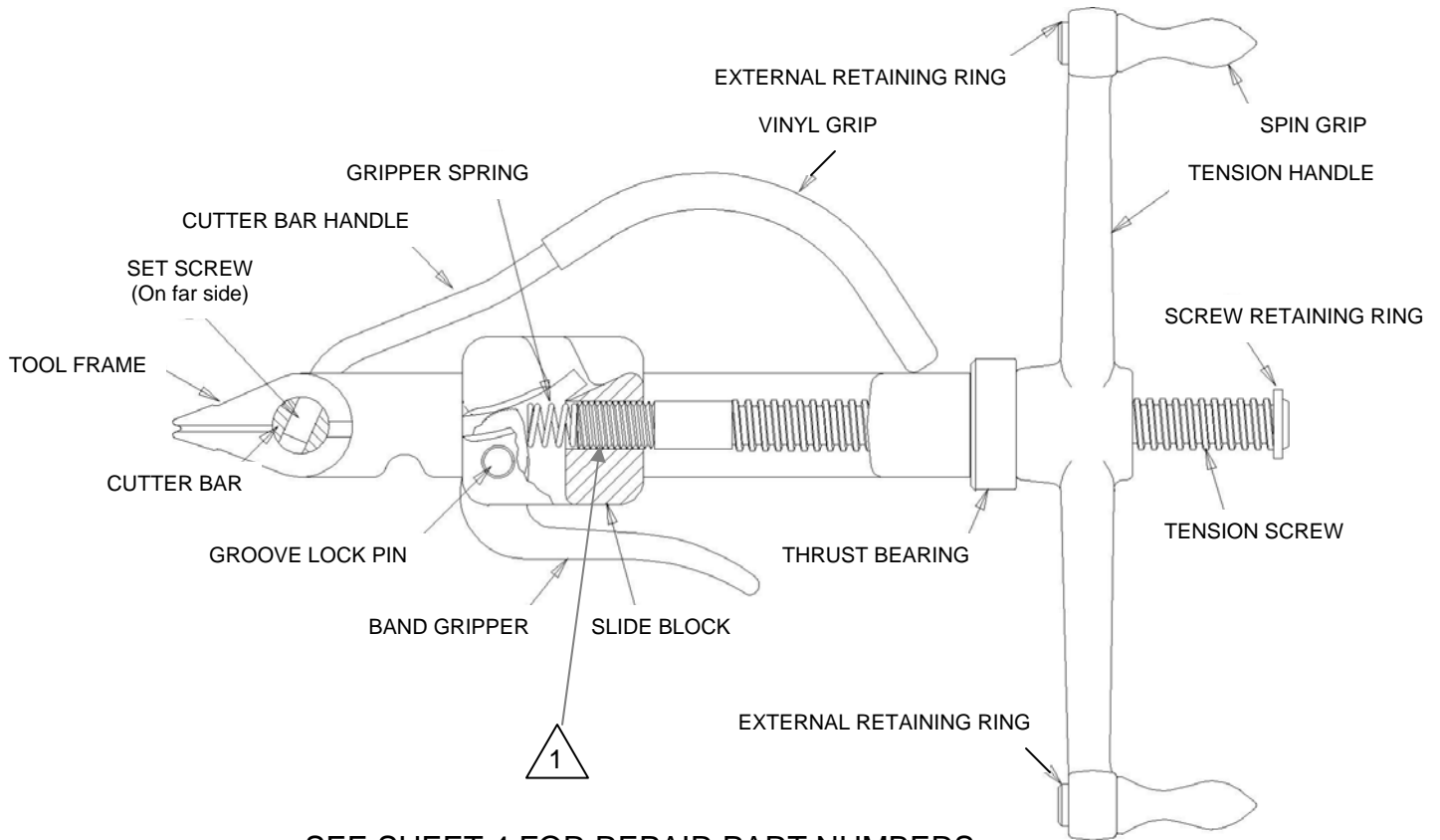

SEE SHEET 4 FOR REPAIR PART NUMBERS

1. To assist in removing threaded parts, apply heat (softens locking compound).

2. When connecting the tension screw to the slide block, clean threads (male and female) of foreign matter, then apply two drops of medium strength locking compound (Loctite 242 or equiv.) onto male threads and connect parts together. Apply .03 oz. of food-grade white lubricant or equiv. to tension screw thread.

3. When connecting the set screw to the cutter bar, clean threads (male and female) of foreign matter, then apply one drop of medium strength locking compound (Loctite 242 or equiv.) onto male thread and connect parts together.

4. Kit # C00689 contains the C02078 Assembly and the C03882 Tension Screw. Both parts should be changed as a set to reduce accelerated wear.

5. Kit # C01899 contains one each of a C01887 band gripper, C03186 gripper spring and C01787 pin. Replace all parts as a new set to maximize tool performance. Periodic cleaning of band gripper teeth will improve tool performance.

REPAIR PARTS LIST FOR C00169	
PART #	DESCRIPTION
C01140	TOOL FRAME
C01687	THRUST BEARING
C01387	SLIDE BLOCK
C01899	KIT, GRIPPER ASSEMBLY INCLUDES: GRIPPER, PIN, AND GRIPPER SPRING
C05887	KIT, CUTTER BAR ASSEMBLY INCLUDES: CUTTER BAR HANDLE, VINYL GRIP, SET SCREW, AND CUTTER BAR
C00689	KIT, TENSION HANDLE AND SCREW

Refer to website for warranty information: <http://www.band-it-idex.com/warranty.html>